



# HAM TIPS



A PUBLICATION OF THE RCA ELECTRON TUBE DIVISION

VOL. 22, NO. 1

©1962, RADIO CORPORATION OF AMERICA

SPRING, 1962

## NUVISTOR TWO-METER TRANSMITTER

By R. M. Mendelson, W2OKO  
RCA Electron Tube Division, Harrison, N. J.

Announcement of a new tube usually starts the construction-minded ham searching for ways to take full advantage of its improvements over older tube types. And when a whole series of new types, such as RCA's nuvistor line, is introduced, the experimental possibilities become almost limitless.

To date, HAM TIPS articles on nuvistor applications have been concerned solely with receiving circuits. (Consider the nuvistor two-meter converter and the nuvistor pre-amplifier, described respectively in the May, 1961, and September, 1961, issues.) Can the amateur make good use of these same receiving tubes in low-power transmitters? Yes! RCA nuvistors are ideal for miniaturized VHF mobile or fixed-station transmitting operation. These tubes have high plate-dissipation ratings for their small size; they are easily usable up to 400 megacycles; and they have the rugged construction required for mobile operation.

The transmitter featured in this issue points up the versatility of RCA nuvistors—and how easily they may be put to work as transmitting tubes. An RCA-7586 nuvistor triode is used in a conventional overtone crystal oscillator at 48 Mc. Unnecessary loading of the oscillator is prevented by operating the tube with no frequency multiplication. The second-stage 7586 triples the frequency to 144 Mc and provides the drive to the final

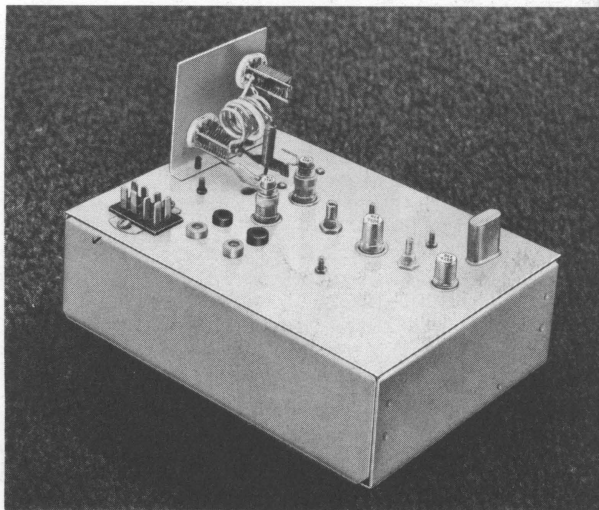

Top view of W2OKO's two-meter transmitter designed around two RCA-7586 nuvistor triodes and a pair of RCA-7587 nuvistor tetrodes.

stage. A pair of RCA-7587 nuvistor tetrodes used in the final amplifier can be operated with a power input of up to 7½ watts. The very low driving power for these tubes is easily supplied by the tripler stage. Screen-grid neutralization is used, but adjustment is not critical.

Figure 1 presents the complete schematic diagram and parts list for the nuvistor two-meter transmitter. Table I shows typical operating voltages and currents.

### Construction

The entire transmitter is built on a 5- by 7-inch piece of copper or brass, so that a standard aluminum chassis may be used as the base cover. A smaller plate can be used without cramping the parts if a special cover is hand bent. (Refer to Figure 2 for the parts

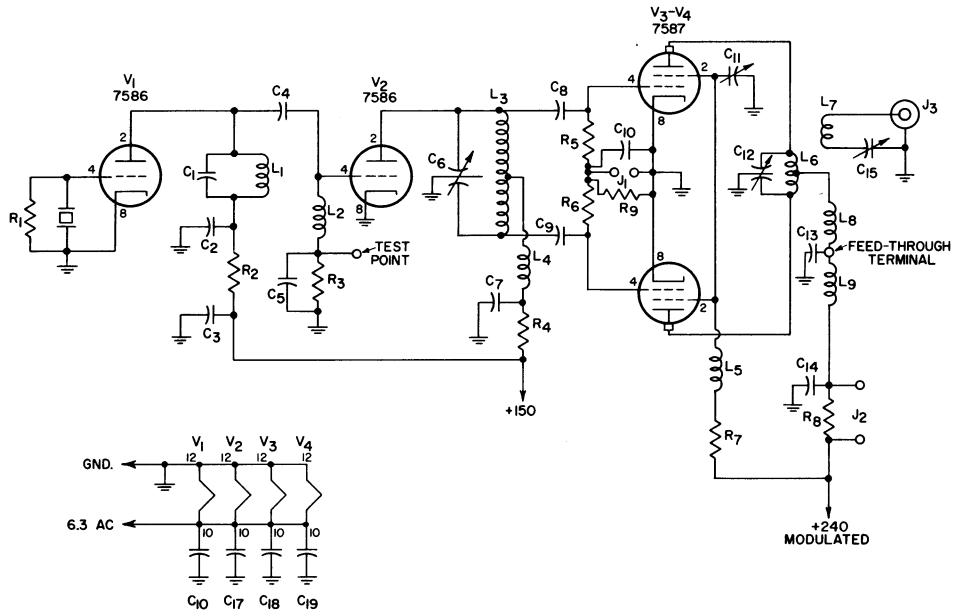

- C<sub>1</sub>—30 pf ceramic tubular (Centralab TCZ-30 or equiv.)
- C<sub>2</sub>, C<sub>3</sub>—.01 μf ceramic disc (Centralab DD-1032 or equiv.)
- C<sub>4</sub>—50 pf ceramic tubular (Centralab TCZ-50 or equiv.)
- C<sub>5</sub>, C<sub>7</sub>, C<sub>10</sub>, C<sub>13</sub>, C<sub>14</sub>, C<sub>16</sub>, C<sub>17</sub>, C<sub>18</sub>, C<sub>19</sub>—500 pf ceramic tubular (Centralab DD-501 or equiv.)
- C<sub>6</sub>, C<sub>12</sub>—2.7-10.8 pf butterfly air capacitor (Johnson 11MB11 or equiv.)
- C<sub>8</sub>, C<sub>9</sub>—20 pf ceramic tubular (Erie TCO-20 or equiv.)
- C<sub>11</sub>—7.45 pf ceramic trimmer (Erie TS-E or equiv.)
- C<sub>15</sub>—3-32 pf air trimmer capacitor (Johnson 30M8 or equiv.)

- J<sub>1</sub>, J<sub>2</sub>—Pair each, insulated phone tip jacks
- J<sub>3</sub>—Coax jack type BNC
- L<sub>1</sub>—4¼ turns #26 enameled wire, ⅜-inch diameter, spaced wire diameter on slug tuned form (CTC LS3 or equiv.)
- L<sub>2</sub>—RFC 7 μh (Ohmite Z50 or equiv.)
- L<sub>3</sub>—4 turns #16 bare wire, ½-inch diameter, ⅝-inch long, tapped at center
- L<sub>4</sub>, L<sub>5</sub>, L<sub>8</sub>, L<sub>9</sub>—RFC 1.7 μh (Ohmite Z144 or equiv.)
- L<sub>6</sub>—5 turns #14 bare wire, ½-inch diameter, ⅝-inch long, tapped at center
- L<sub>7</sub>—1 turn #14 bare wire, ¼-inch diameter, insulated with "spaghetti"

- R<sub>1</sub>—100,000 ohm, ½ watt
- R<sub>2</sub>, R<sub>4</sub>—5,600 ohm, ½ watt
- R<sub>3</sub>—15,000 ohm, ½ watt
- R<sub>5</sub>, R<sub>6</sub>—6,800 ohm, ½ watt
- R<sub>7</sub>—27,000 ohm, ½ watt
- R<sub>8</sub>—100 ohm, ½ watt
- R<sub>9</sub>—1,000 ohm, ½ watt
- Crystal socket
- Feed-through terminal
- Crystal—48.0-49.33 overtone (International Crystal Co. type FA5 or equiv.)
- 4 nuvistor sockets (Cinch No. 133 65 100.011)
- 1 socket (Jones type P308 AB or equiv.)
- 1 chassis, aluminum, 5" x 7" x 2" (Bud AC402 or equiv.)

Figure 1: Schematic diagram and parts list.

layout that assures short leads and correct parts orientation. Also see Figure 3 for a sketch of the small bracket to be used in mounting the final tank circuit and output coaxial connector.)

Because of their small size, nuvistor sockets are clamped, not bolted, to the chassis by bending two lugs on the socket. After the chassis hole has been drilled, two notches for the lugs are hand filed to insure a tight fit of socket to chassis. For rf grounding, both socket lugs are soldered to the chassis plate.

Adequate rf bypassing is applied to all critical parts of the circuit. Because the reliability of nuvistors makes it unnecessary to retune the transmitter every time it is put into service, a permanent meter is not required. Rather, two pairs of jacks are used for

plugging a temporary meter into the grid or plate circuits of the final. An eight-contact power socket provides extra contacts for future development.

The plate caps for the tetrode are made by bending a piece of piano wire into a tight-fitting one-turn coil. To keep lead inductance low, the leads to the plate tank capacitor are made from ¼-inch-wide copper ribbon. The one-turn output link is covered with a piece of "spaghetti" insulation and tightly coupled to the final tank coil.

### Adjustment

The transmitter is very easy to tune. If all the coils have been wound to specification, there should be no trouble in finding the proper settings of the coil slug and of the

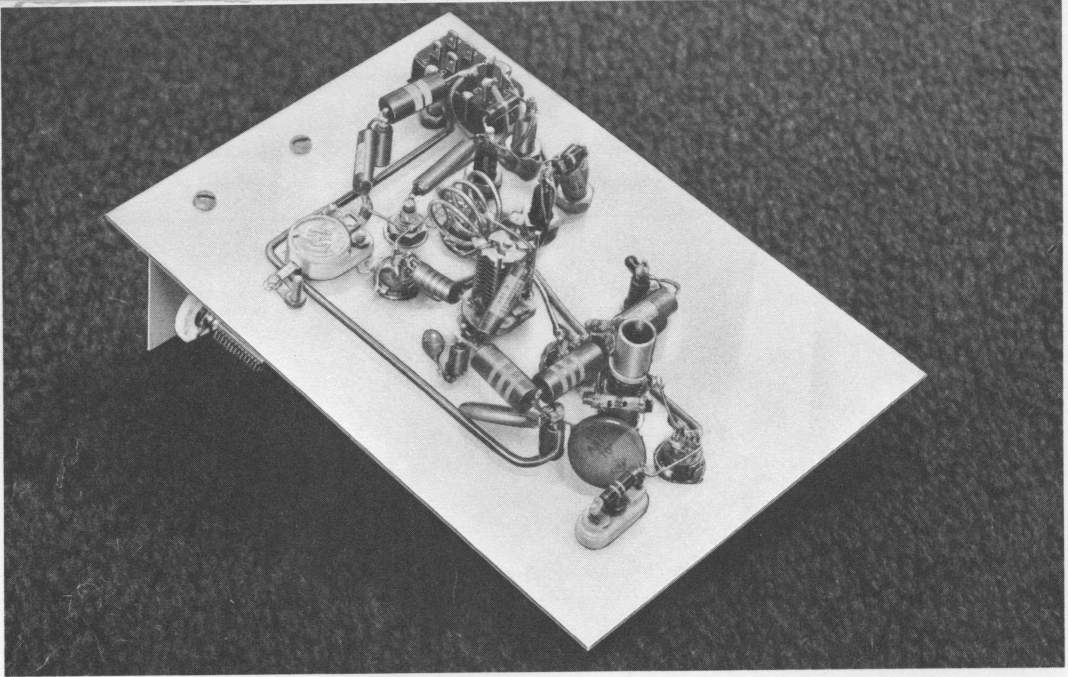

Bottom view of author's nuvistor two-meter transmitter.

tuning capacitors. Of course, a grid-dip meter makes tuning even easier.

To assure that the oscillator will start every time voltage is applied, follow this procedure: Plug in only the first RCA-7586 and the crystal; apply heater voltage and +150-volt plate voltage, and allow the tube to warm up. With a high-impedance voltmeter applied to the test terminal, adjust the slug in coil  $L_1$  until oscillation starts (shown by voltage at the test point). Adjust for maximum voltage; then back the slug out to give a slightly higher tuned frequency. A reading of about 10 volts should be obtained.

Next, plug in the second RCA-7586 and the two RCA-7587's. Do not apply plate and screen-grid voltage to the final as yet. Plug a

5-milliamper meter into the grid jack pair,  $J_1$ , and tune  $C_6$  for maximum grid current. A reading of between 2 and 3 milliamperes should be obtained.

Then, rotate the plate-tuning capacitor,  $C_{12}$ , through its entire range. There should be very little effect on the grid-current reading. In turn, slowly adjust the screen-grid bypass capacitor,  $C_{11}$ , while rotating the plate capacitor until a point is found at which the plate capacitor has no effect on the grid current. This adjustment is not critical.

Now that the final stage is neutralized, plug a 50-milliamper meter into the final plate-circuit pair,  $J_2$ ; attach the antenna or dummy load, and apply +240 volts to the plate and screen-grid circuit. Tune the plate

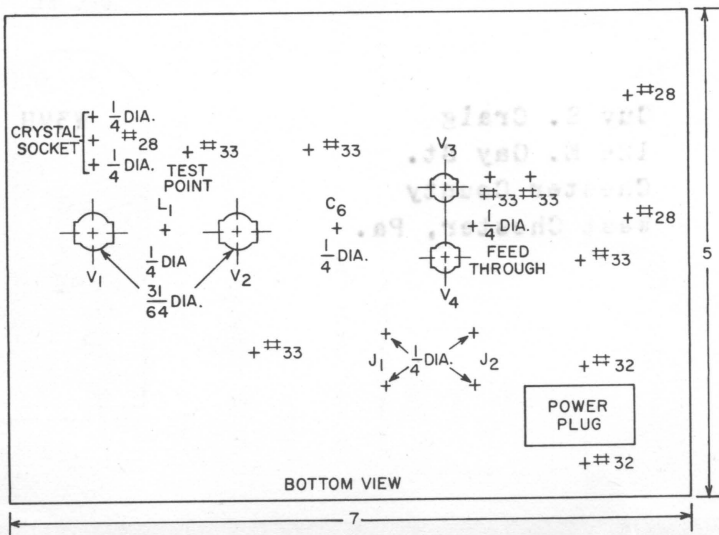
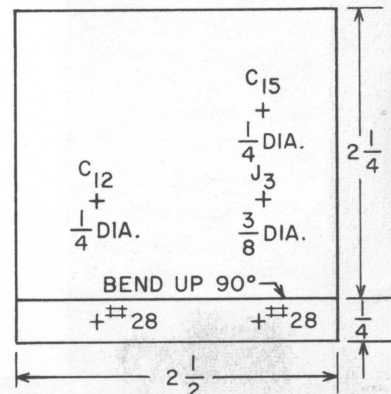

Figure 2 (at left): Bottom view of chassis plate (one-half actual size).

Figure 3 (below): Diagram for the final-stage mounting bracket.



# HAM TIPS NOW AVAILABLE ON SUBSCRIPTION BASIS

Radio amateurs consistently ask RCA how they may obtain each new issue of HAM TIPS, published quarterly. If you're not already receiving this publication regularly from your RCA Electron Tube Distributor, you may be interested in being added to RCA's new direct-mail list of HAM TIPS subscribers who reside in the United States and its possessions (including APO and FPO numbers).

A two-year subscription to HAM TIPS is now offered to you for the minimum charge of only \$1.00 (one dollar) to cover

postage and handling of the eight issues. All you need do is type or print your name and address on the "Subscription Request" form below; then mail this envelope with your check or money order (no cash or stamps, please) to:

Radio Corporation of America  
Section 882

Harrison, New Jersey

When ordering, be sure to enclose your remittance—payable to the Radio Corporation of America.

## HAM TIPS SUBSCRIPTION REQUEST

\_\_\_\_\_ Date

### Gentlemen:

I wish to enter my name for a two-year subscription to HAM TIPS.

Enclosed please find my check or money order for \$1.00, payable to the Radio Corporation of America.

NAME \_\_\_\_\_  
(Please type or print)

STREET ADDRESS \_\_\_\_\_

CITY \_\_\_\_\_ ZONE \_\_\_\_\_ STATE \_\_\_\_\_

**RADIO CORPORATION OF AMERICA  
SECTION 882  
HARRISON, NEW JERSEY**

**AFFIX  
STAMP  
HERE**

TABLE I: TYPICAL OPERATING VOLTAGES AND CURRENTS

(All voltages are measured with respect to ground and may vary by 20%)

<u>Voltage to ground</u>	<u><math>V_1</math></u>	<u><math>V_2</math></u>	<u><math>V_3, V_4</math></u>
Plate	100	86	240 Volts
Screen Grid	—	—	75 Volts
Control Grid*	-9.5	-9.2	-15.1 Volts
Cathode	0	0	0 Volts
<u>Currents</u>			
Control Grid Final	—	—	2.3 Milliamperes
Screen Final	—	—	5.0 Milliamperes
Plate Final	—	—	32.0 Milliamperes

\*Measured with vacuum-tube voltmeter. A low impedance meter will affect the circuit values.

tank for minimum plate current with capacitor  $C_{12}$ . The tuning capacitor,  $C_{15}$ , in the output link is for balancing out feed-line reactance to the antenna and should be adjusted for best output. (Use a standing-wave-ratio bridge, a field-strength meter, or even signal-reports from another station.) When fully loaded, a plate current of about 32 milliamperes should be obtained.

### Conclusion

Only after using this transmitter will the operator realize the merits of nuvistor ruggedness and reliability. Long periods of operation, or even long periods of idleness, have no effect on the nuvistor transmitter. It will stay tuned and ready to work well whenever needed.

Information furnished by the Radio Corporation of America is believed to be accurate and reliable. However, no responsibility is assumed by RCA for its use; nor for any in-

fringements of patents or other rights of third parties which may result from its use. No license is granted by implication or otherwise under any patent or patent rights of RCA.



From your local  
RCA distributor,  
headquarters for  
RCA receiving  
and power tubes.

RCA HAM TIPS  
is published by the  
RCA Electron Tube  
Division, Harrison,  
N. J. It is available  
free of charge from  
RCA distributors.

Harvey Slovik, Editor

GEORGE D. BARBEY CO., INC.  
Reading Pottstown  
Lancaster Lebanon

WHEN MAILING  
PLACE POSTAGE HERE